

Coordinated Circuit Protection Strategies Help Prevent Damage to USB Charger Systems and Portable Electronics

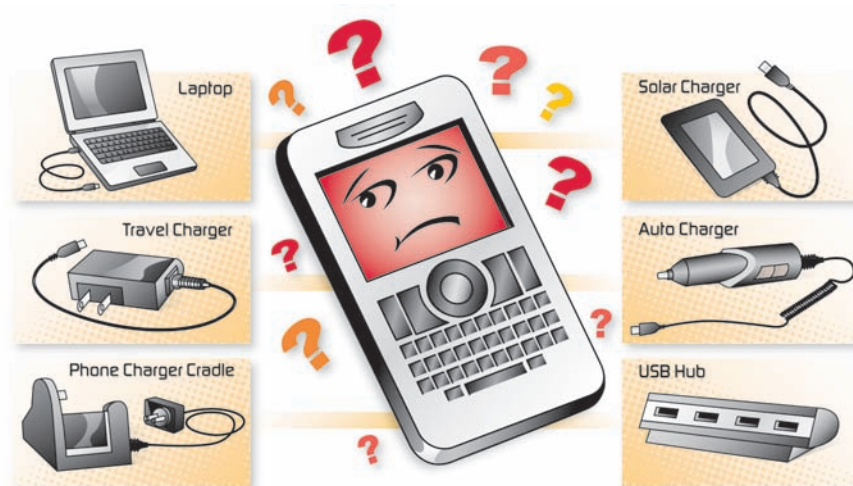

For portable consumer electronics, USB (Universal Serial Bus) has become the most popular and pervasive connectivity technology. As the adoption of this standard has grown, USB connected devices have begun to cover a broader range of hardware applications. The trend toward using USB's power capabilities to charge batteries on portable devices has resulted in a demand for industry-standard approaches and has led to new specifications being published by the USB-IF (USB Implementers Forum).

With the introduction of several new and proposed technologies such as USB Charger, manufacturers are faced with a challenge as well as an opportunity. The challenge is the need to meet all of the new USB specifications and still keep costs low. The opportunity is to improve the consumer experience through faster charging speed and universal charging.

The USB 2.0 specification identifies two types of power sources for battery charging: the dedicated charger (or wall charger) and the host or hub charger. The host and hub chargers utilize similar circuitry for charging and data enumeration. Because each of these power sources utilizes a

mechanically identical connection – even though their power characteristics are quite different – power source detection is a critical design consideration.

USB devices (1.0 and 2.0) utilize 4 pins for connectivity: V_{BUS} (+5v), ground, Data – and Data +, as shown in Figure 1. The V_{BUS} and ground provide the power source for the connected device or the current/voltage for charging the connected device. D- and D+ are the communication channels and adhere to very specific procedures for enumeration. Upon being attached to a host, hub or USB charger, the portable device detects a voltage on the V_{BUS}. The portable device must then determine what it is attached to and limit its current appropriately.

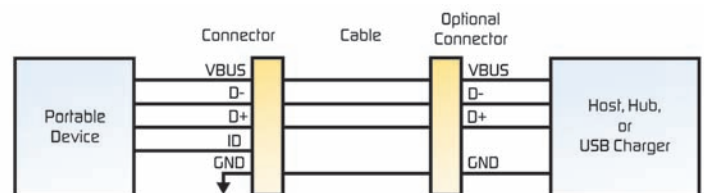

Figure 1. The USB charger specification utilizes the same pinouts as USB 2.0 but allows for higher current capability.

Higher Current, Higher Risk

Although power via USB has been in use for some time, the new standard dramatically increases the amount of current that can flow to a USB device – to a new maximum current rating of 1.5A (instead of 0.5A for USB 1.0 and 2.0). These higher current applications require more reliable and robust circuit protection to help prevent damage caused by overvoltage transients and overcurrent conditions.

Overvoltage transients are generally caused by ESD (electrostatic discharge) and may occur on both the power bus as well as the data lines. Although modern ICs are

protected up to 2000V, a human body can easily build up static charge that ranges up to 25,000V. In I/O port protection applications, a very low capacitance ESD device with fast clamping and recovery response is required on the data lines.

Overcurrent conditions can also affect the power bus. The circuit protection requirement here is the ability to handle inrush currents (up to 1.5A per port for USB charging) reliably, and limit current faults below 5A in 60 seconds in the event of a fault (UL 60950 Table 2C).

Protecting Dedicated Chargers

When a portable device is connected to a dedicated charger and detects that D+ and D- are shorted, the device allows a maximum charging current of 1.5A. A pure charging device, the dedicated charger only provides power via the USB connector and is not capable of data communication. Figure 2 illustrates how a PolySwitch device on the V_{BUS} helps prevent overcurrent damage caused by a sudden short circuit downstream of the charger (i.e. on the device side).

PolySwitch devices provide the resettable functionality, small size, fast time-to-trip, and low power dissipation required in a wide variety of USB 2.0 applications. They also help meet the new high-current requirements of the USB charger specification and provide a simple, cost-effective solution for high-density circuit board designs.

USB charging must support a minimum steady state current of 1.5A per port reliably, and limit current below a maximum 5A in 60 seconds in the event of a fault (UL60950 Table 2C). We recommend the following solutions for protection of host/hub and portable devices, from overcurrent and overvoltage damage, when connected to dedicated chargers:

Host/Hub

A PolySwitch nanoSMDC200S device or miniSMD260F device, per port, is recommended in case of USB charging.

Portable Device

A PolyZen ZEN056V230A16LS device or ZEN065V230A16LS device is recommended in case of USB charging.

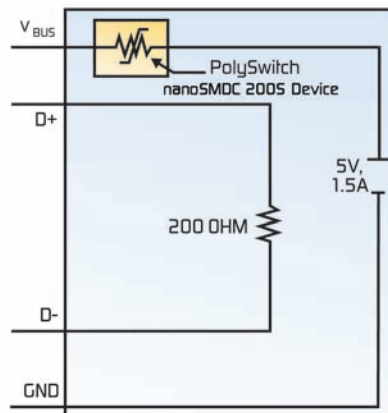

Figure 2. Overcurrent protection scheme for dedicated USB charger.

Protecting Host/Hub Chargers

In the case of host/hub chargers, the portable device may not cause the voltage to drop below 2.0V under normal operating conditions. It must limit the amount of current drawn from a host/hub charger to 1.5A at low speed or full speed or to 0.9A at high speed.

Low-cost solutions use PolySwitch devices to help meet USB and UL60950 overcurrent protection requirements. In traditional USB, with a 0.5A current limit, one can protect up to four ganged ports with a single PolySwitch overcurrent

protection device, and still supply 0.5A per port with response to current over 5A. USB charging must support 1.5A per port and still respond to currents over 5A, to meet UL60950 requirements. As such, we recommend each individual port include current limiting circuitry as shown in Figure 3.

USB overvoltage protection devices designed for traditional 0.5A ports may also be inadequate for the new USB charging specification of 1.5A per port.

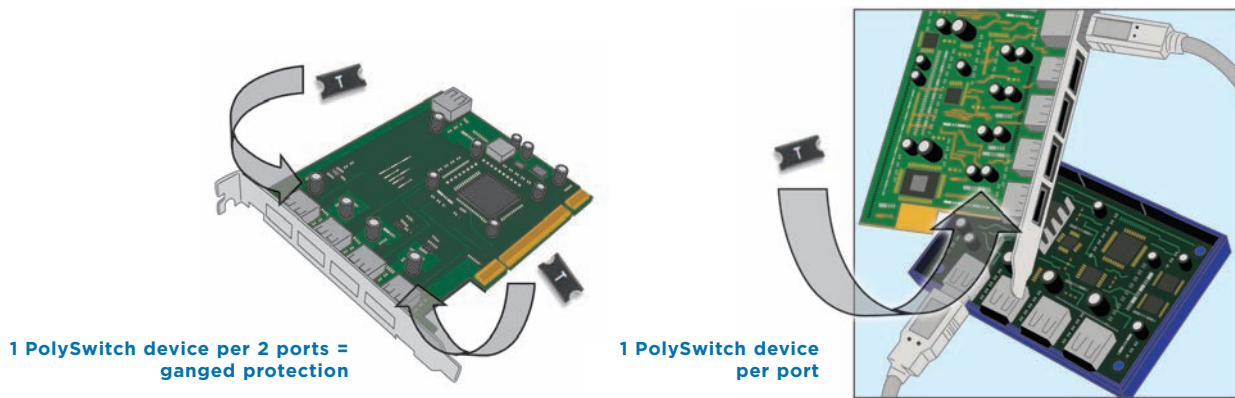

Figure 3: Host/Hub charger with single PolySwitch device for 2-ganged ports, and single PolySwitch device per port for USB applications.

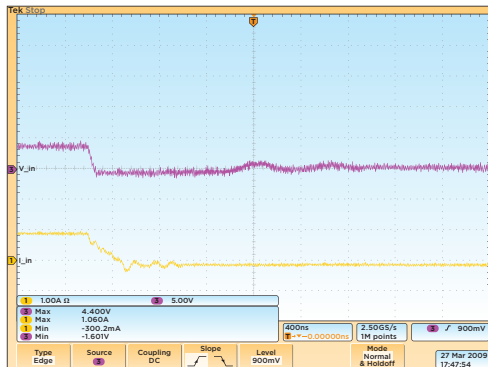

Figure 4a. Typical overvoltage event in a USB 2.0, 4-port ganged application.

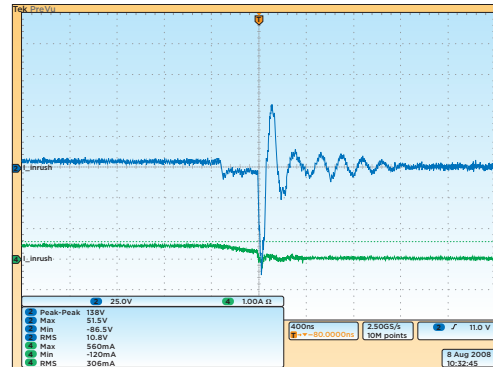

Figure 4b. Typical overvoltage event in a USB 3.0, 2-port ganged application.

As shown in Figures 4a and 4b, 1.5A hot disconnects can generate significantly high inductive spikes that can affect the devices left on the bus. A well designed bus will absorb these spikes and protect devices from exposure to them. Installing a PolyZen device on the bus can help protect devices from inductive loads. Additionally, the PolyZen device's form factor meets the board-space and surface-mount installation requirements of new portable electronics designs.

A coordinated circuit protection strategy for protecting host or hub chargers is shown in Figure 5. The PolySwitch device helps protect against overcurrent damage on the V_{BUS} line, and PESD devices are used to shunt ESD away from sensitive circuitry on the data lines. PESD devices provide low capacitance compared to traditional MLV (multilayer varistor) or TVS (transient voltage suppression) diode technology. Their low-trigger voltage and low-clamping voltage also helps protect sensitive electronic components.

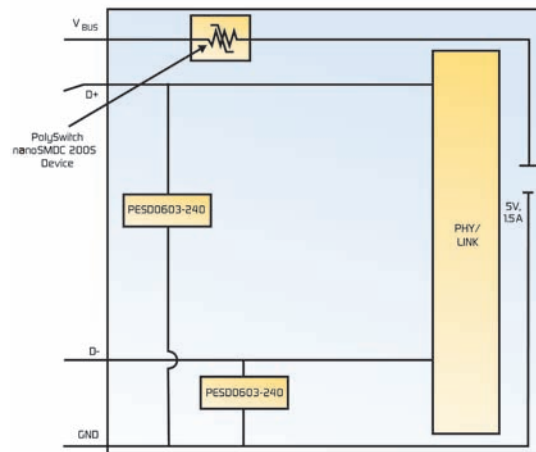

Figure 5. Host and hub chargers require coordinated overcurrent and overvoltage circuit protection.

Overcharge Considerations

As per the recommendations of IEEE 1725-2006 standard for rechargeable batteries in cellular telephones and the Cellular Telecommunications and Internet Association (CTIA), the maximum charging voltage and current should be set on the basis of agreements made among cell, battery pack and host device manufacturers and shall be based on upper voltage and current limits of the cell, as specified by the cell manufacturer.

Some high-volume customers have indicated that they design their USB 2.0 systems to withstand up to 16V (some systems must be designed to withstand up to 24V) in order to minimize damage & returns caused by voltage transients. Due to the higher currents allowed in the USB charger specification and increased potential for poorly regulated third-party chargers, these high-volume customers may need to increase this value.

Polymer-enhanced Zener Diode Helps Protect Portable Electronics Charged Via USB Ports

GPS systems, smart phones, play stations and portable media players that can be charged in the home, office or car may be exposed to voltage or current transients every time they are connected or disconnected. The evolution of mobile multimedia equipment from audio-centric devices to video-centric storage devices has also resulted in higher power requirements, higher data transmission rates and smaller circuitry.

Multiple interfaces and charging systems can expose portable devices to damage caused by the use of incorrect chargers, improperly regulated third-party chargers, or hot connect/disconnect events. Although typical USB supplies provide regulated lines at 5V +/- 5%, the voltage at these lines may, under certain circumstances, exceed 5.25V, resulting in damage to the system or unprotected peripherals. As shown in Figure 6, a device may experience voltage spikes as high as 88.5V (141 V p-p) when connected to a third-party charger.

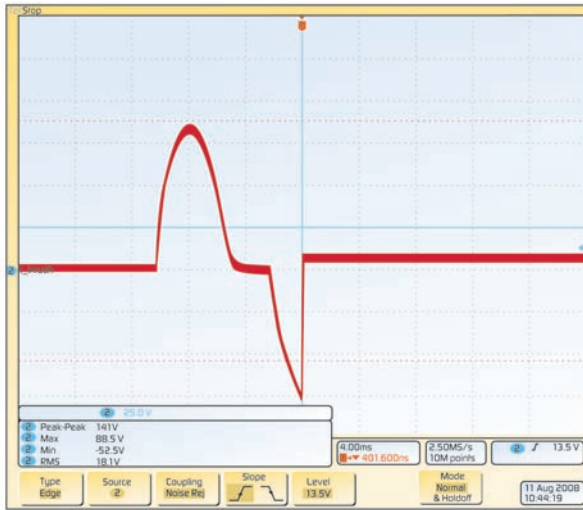

Figure 6. Voltage spike across a device connected to third-party charger
Max: 88.5 V, Time period: 7 ms .

As shown in Figure 7, polymer-protected Zener diode micro-assemblies incorporate a stable Zener diode for crisp voltage clamping and a resistively non-linear PPTC (polymeric positive temperature coefficient) layer. The PPTC layer responds to either diode heating or overcurrent events by transitioning from a low to high resistance state. In the event of a sustained high-power overvoltage condition, the tripped PPTC element limits current and generates a voltage drop to help protect both the Zener and the follow-on electronics – effectively increasing the diode’s power handling capability.

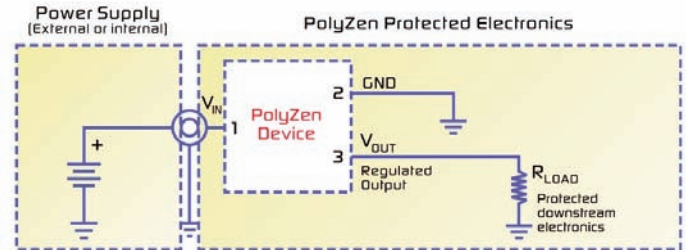
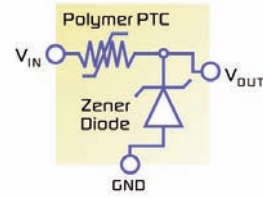

Figure 7. Tyco Electronics' PolyZen device helps provide input power protection for portable electronics.

This device is particularly effective at clamping and smoothing inductive voltage spikes. In response to an inductive spike the Zener diode element shunts current to ground until the voltage is reduced to the normal operating range. In the case of a wrong voltage power supply, the device clamps the voltage, shunts excess power to ground, and eventually locks out the wrong supply.

Figure 8 shows a coordinated overcurrent/overvoltage protection strategy for portable electronic devices utilizing a PolyZen device, to help protect against damage caused by overcurrent and overvoltage conditions, and PESD devices to help protect against damage caused by overvoltage transients.

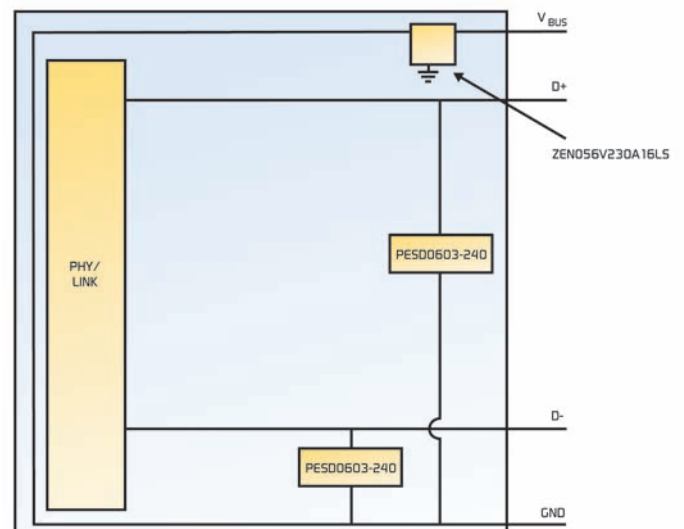

Figure 8. Coordinated protection strategy for portable electronics device.

Protection Recommendations

For traditional USB 2.0 host and hub charger applications, Tyco Electronics recommends the PolySwitch miniSMDC110 device for single port connections, the PolySwitch miniSMDC150 device for 2-port connections and the PolySwitch nanoSMDC200S device for 3-port connections. To help protect traditional 0.5A USB peripherals from overvoltage surges on V_{BUS} , Tyco Electronics recommends PolyZen ZEN056V130A24LS and ZEN065V130A24LS devices.

For new USB charging applications, including dedicated chargers, hosts and hubs, Tyco Electronics recommends PolySwitch nanoSMDC200S devices for overcurrent protection on each port. To support new 1.5A charging on the device side Tyco Electronics recommends, PolyZen ZEN056V230A16LS devices on the V_{BUS} line.

PESD0603-240 devices, on all D+ and D- line devices and host/hub, independent of USB 2.0 or USB charging, are also recommended.

Protection requirements are application-dependent and designers must decide what level of protection is required for their application. Recommendations from device manufacturers are useful in narrowing protection options and benchmarking other port protection schemes may provide a good path for further investigation. However, specific testing of each protection option is the best way to evaluate its effectiveness.

Summary

New charging technologies will enhance the convenience of portable electronic devices. However, these higher current applications will require more robust circuit protection to help prevent damage caused by overvoltage transients, and sustained overvoltage and overcurrent conditions. Tyco Electronics offers a wide range of coordinated and integrated circuit protection solutions for dedicated chargers, as well as host and hub charging applications.

Raychem Circuit Protection Products

308 Constitution Drive, Building H
Menlo Park, CA USA 94025-1164

Tel : (800) 227-7040, (650) 361-6900
Fax : (650) 361-4600

www.circuitprotection.com

www.circuitprotection.com.hk (Chinese)

www.tycoelectronics.com/japan/raychem (Japanese)

miniSMD, nanoSMD, PolySwitch, PolyZen, Raychem, TE logo and Tyco Electronics are trademarks. All information, including illustrations, is believed to be reliable. Users, however, should independently evaluate the suitability of each product for their application. Tyco Electronics Corporation makes no warranties as to the accuracy or completeness of the information, and disclaims any liability regarding its use. Tyco Electronics' only obligations are those in the Tyco Electronics Standard Terms and Conditions of Sale for this product, and in no case will Tyco Electronics be liable for any incidental, indirect, or consequential damages arising from the sale, resale, use, or misuse of the product. Specifications are subject to change without notice. In addition, Tyco Electronics reserves the right to make changes without notification to Buyer—to materials or processing that do not affect compliance with any applicable specification.

© 2009 Tyco Electronics Corporation. All rights reserved. RCP0052E.0509



Tyco Electronics

Our commitment. Your advantage.